

AERONAUTICAL SOLUTIONS

For aircraft access



Discover
our solutions
in pictures

 **MANITOU**
HANDLING YOUR WORLD

AERONAUTICAL
SOLUTIONS

LONG-TERM PARTNER FOR A DEMANDING WORLD

For many years, major actors in the aeronautical sector have trusted Manitou Group to develop innovative solutions responding to their specific needs and constraints. From the line to engines MRO (Maintenance, Repair and Overhaul), for indoor or outdoor use, Manitou Group delivers the dedicated answers to its esteemed customer.

The group researches, designs, and manufactures a wide range of dedicated electric and combustion engine machines well known for their reliability, performance and robustness.

Our network of 1,050 expert dealers provides you with services essential to your business, including after-sales support, maintenance, training and financing.

With capacities from 0,5 to 23 tons (t) and lift heights from 4 to 43 meters (m), Manitou Group has the solution to all your aircraft access and logistical challenges.





AERONAUTICAL
SOLUTIONS

AIRCRAFT ACCESS

Gain fluency in working

Manitou offers you a range of unique solutions which combines personnel lifting and material handling. It meets the specific needs of military and civil aviation to increase machine utilization and make operations safer





Precision and rapidity

- Proportional lifting and lowering
- Video camera (x4) to increase visibility
- Aerial jib for telehandlers and MEWP's up to 300 kg lifting capacity
- Adjustable basket (3D system) to get around obstacles smoothly



Personnel and aircraft safety

- Machine stability and rigidity
- Driving assistance system via ultrasonic sensors avoiding risk of collision with aircraft
- Bi-energy system for indoor and outdoor uses, for more autonomy

Large range of MEWP's and telescopic forklifts as well as **advanced equipments upon request:** attachment recognition, electrical and pneumatic supply in the basket



SE

Mewp scissor lifts

3 models

8-10-12 m

Max. basket capacity

350 kg (2 operator)

2 maintenance-free AC

Integrated diagnostic

Full-height swing gate

Comfort

- Easy-to-fold-down guardrails to quickly change configuration for greater versatility
- Extension of the platform guided smoothly by rollers to increase the working surface

Safety

- Natural and safe access for the operator thanks to the full-height swing gate
- In the working position, perfect stability, whatever the ground conditions, ensured by the mechanical anti rollover bars



High durability

- Our structures recognized for their rugged design and long-term durability
- Closed joints at the ends to prevent water infiltration and, consequently, corrosion

Performance

- Precision of the movements increased by the electric transmission for more agility of the machine
- Competitive lifting and lowering speeds ensured by the powerful pump motor

Reduced maintenance

- Maintenance-free of the scissor arm connection points
- Specific design of the swivel bins to prevent water infiltration due to bad weather
- Protection of the components by high quality plastic covers
- AC/DC motors controlled by a single drive for greater simplicity

Saving time for the rental market

- Side sleeves for a safe alternative for lorry loading and unloading and to be moved over long distances using a forklift truck

**Low maintenance costs
and simple robust design**



VJR - V'AIR

Vertical mepw's

Max. outreach

2.5 m

Max. working height

10 m

Basket capacity

230 kg

2 operators

**EVOLVING
TO SERVE YOU
BETTER**

Precision Comfort

- Proportional lifting and lowering
- Rigidity of the mast improving the positioning and stability of the basket

Mobility Visibility

- Machine fitted with a beacon and road lights for taxiway travel
- Fork sleeves to facilitate loading and moving the machine

Safety Ergonomics

- Basket with multiposition openings
- Tilt and load sensors + ultrasonic sensors
- Intuitive control pannel
- Removable and swiveling working light

Compactness Efficiency

- Small footprint
- Smooth driving and accurate steering
- Small turning radius

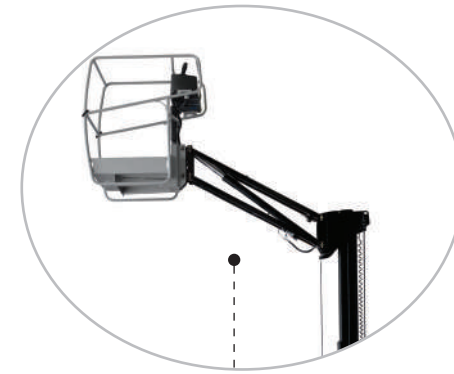
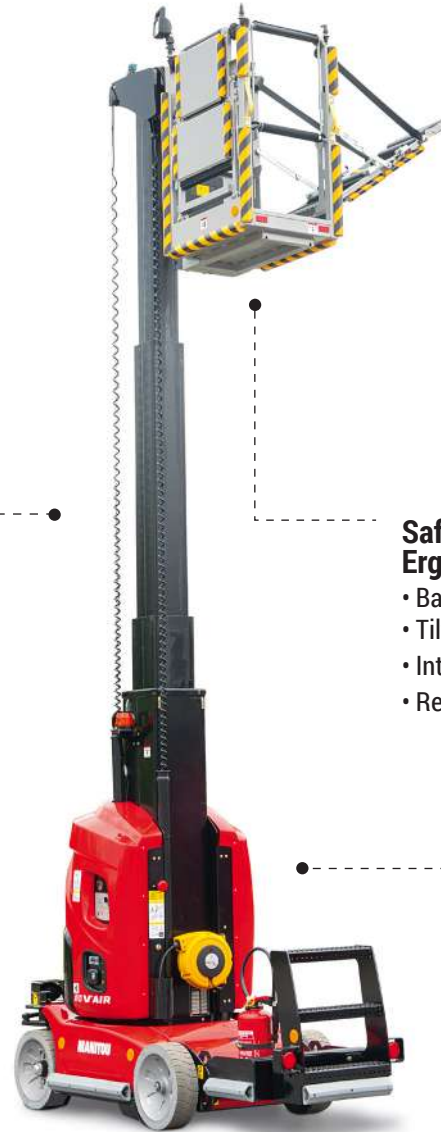

Accessibility

- Working outreach of up to 3.25 m on models 80 and 100 VJR
- Tilting angle: greater access and for easier load placement in the work area
- Optional narrow basket

**Compactness and maneuverability
for superior accuracy**



Safety Comfort

- Up to 400 kg / 3 operators without any working area limitation
- Proximity sensors on the basket and the boom: movement cut-off
- Basket fitted with foam and rubber protectors
- Optional plexi plate against FOD* and hatch on floor



Performance Flexibility

- 3D function: 160° lateral rotation without impacting the basket's rated capacity or the number of on-board operators
- Rotation driven by a hydraulic motor ensuring and excellent precision and reliability
- Constant rotation available on the ATJ range for more smoothness of operation

ATJ - AETJ

Articulated mowp's

Max. outreach

12 m

Max. working height

12 to 20 m

2 energy modes

Electricity
Diesel

Comfort Precision approach

- Reinforced design of the structure contributing to the rigidity of the arm: a reference in its category
- Cylinder limit switch automatically slowed down to prevent shocks being retransmitted into the basket

Overcome any obstacle

*Foreign object damage



Safety Easy to use

- Proximity sensors on the basket and the chassis: movement cut-off
- Big basket fitted with foam and rubber protectors
- Intuitive control pannel

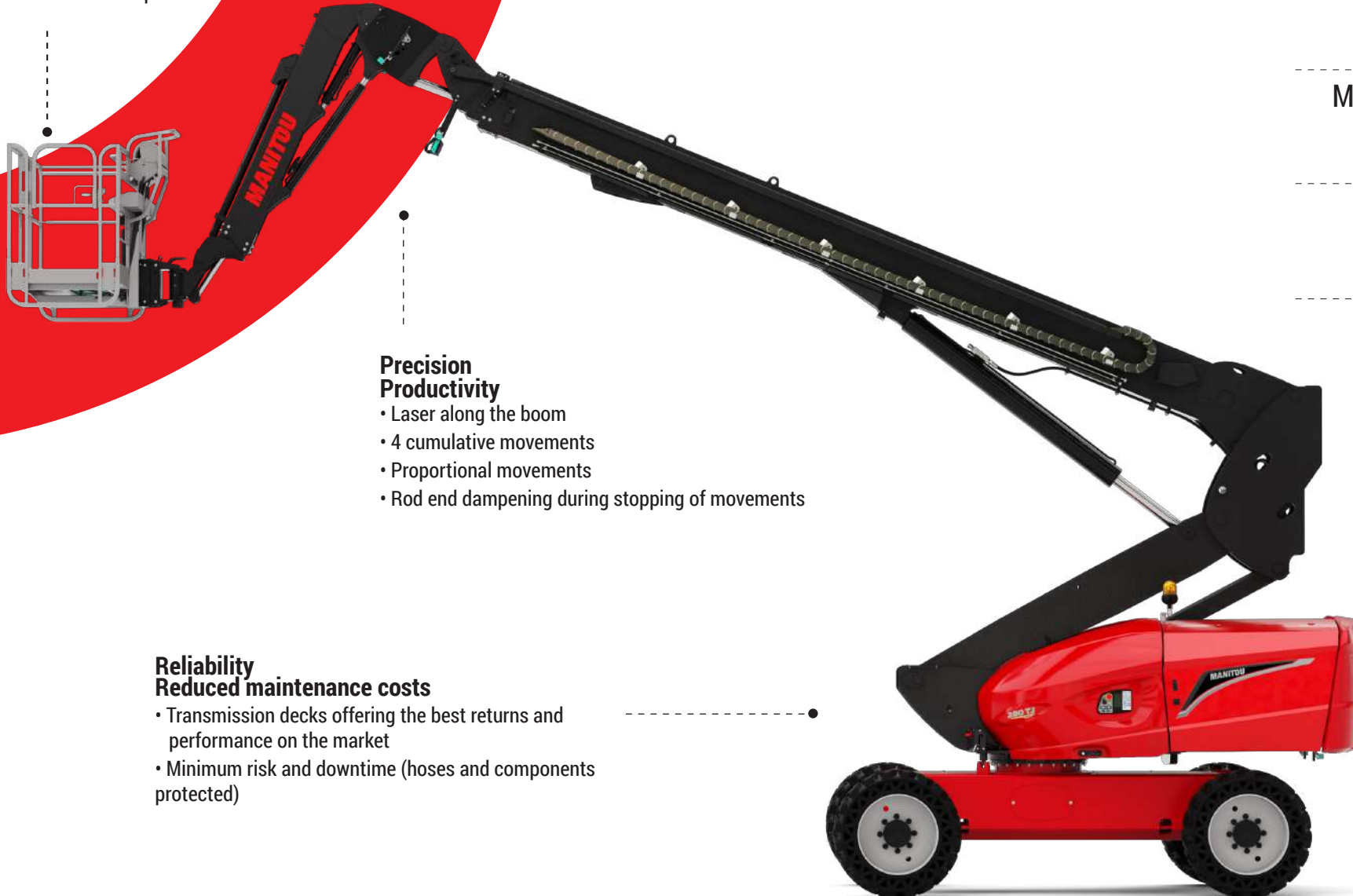

Precision Productivity

- Laser along the boom
- 4 cumulative movements
- Proportional movements
- Rod end dampening during stopping of movements

Reliability Reduced maintenance costs

- Transmission decks offering the best returns and performance on the market
- Minimum risk and downtime (hoses and components protected)

TJ

Telescopic mowp's

Max. outreach

21.4 m

Max. working height

27.7 m

Basket capacity

400 kg

3

operators

Reach new heights



MT - MRT

Fixed or rotating telehandlers

Max. outreach

21.7 m

Max. working height

27.7 m

Capacity up to

6 t

3 energy modes

Electricity
Diesel
Bi-energy



Comfort Serenity

- Rigidity of the boom
- Up to 27,7 m working height
- Light curtain along the boom
- Load limiter cut off system
- Working lights around and under the basket

Functionality Safety

- Basket capacity up to 600 kg / 3 operators
- Jib capacity up to 450 kg
- Movement cut-off when obstacles are detected
- Videocam to improve visibility below the basket
- Optional pneumatic, water and electrical power source
- Hatch on basket floor improving accessibility to the aircraft

Versatility Productivity

- 3 machines in 1
(telehandler, platform modes and
lifting device suspended load)
- 4 steering wheels
- Up to a speed of 36 km/h
- Bi-energy for indoor and outdoor uses

Versatility and rapidity

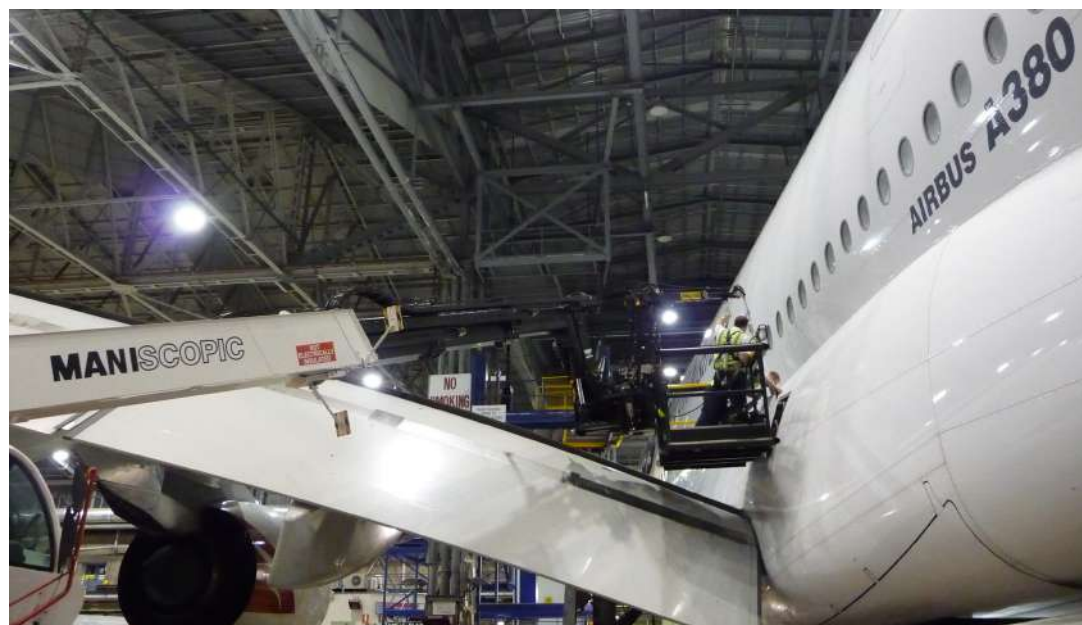

AERONAUTICAL
SOLUTIONS

STORAGE & WAREHOUSING

Responding to the needs of your team is essential

Loading and unloading, placing and removal of material safely, storing goods, stacking and placing in warehouses and preparing shipments are vital operations to support forces on the ground.



Simple for daily handling

Designed for any type of ground surface, easy to maintain, easy to use, ergonomic.

If you want greater versatility, select from these quick change attachments: forks, jib with hook, drum handler...





A global material handling offer

- From the **manual and electrical pallet trucks** to the **masted forklift** through to the **truck mounted forklift** and the **order picker**
- **High manoeuvrability & stability**
- **Semi-industrial forklifts: good gradeability** for indoor and outdoor operations

AERONAUTICAL
SOLUTIONS

FOR AIRCRAFT ACCESS



90 V'AIR
9 m / 230 kg / 2.03 m*



160 ATJ+
16.21 m / 408 kg / 8.52 m*

160 ATJ+e
16.21 m / 408 kg / 8.34 m*

180 ATJ
18.19 m / 230 kg / 10.51 m*

180 ATJ e
18.19 m / 250 kg / 10.33 m*

200 ATJ-(X)
20.35 m / 230 kg / 12 m*

200 ATJ e
20 m / 250 kg / 11.57 m*

120 AETJ-C 3D
11.95 m / 200 kg / 7 m*

150 AETJ-C
15 m / 200 kg / 7.60 m*

170 AETJ-L
16.90 m / 200 kg / 9.43 m*



100 VJR
9.85 m / 200 kg / 3.15 m*



SE 0808
7.8 m / 230 kg*

SE 1008
9.99 m / 230 kg*

SE 1212
11.8 m / 230 kg*



Click on one
of the QR code to get
technical data



MT-(X) 1440 HA

14 m / 4.0 t / 9.46 m**

MT-(X) 1840 HA

18 m / 4.0 t / 13.08 m**



220 TJ-XP

21.74 m / 408 - 350 kg / 17.79 - 17.78 m*

260 TJ

25.89 m / 408 kg / 19.70 m*

280 TJ-X

27.73 m / 240 kg / 21.45 m*



MRT-(X) 2260

23.70 m / 6.0 t / 18.20 m**

MRT-(X) 2660

27.70 m / 6.0 t / 21.70 m**

*Working height / platform capacity / Max. outreach

**Working height / capacity / Max. outreach

OUR MISSION YOUR SAFETY

To meet your safety challenges, discover the solutions we have developed in collaboration with major players in the rental industries.



Operation Safety System OSS



How can you prevent the main causes of accidents associated with telehandlers or MEWPs, such as falls, instability and collisions?

Using attachments, sensors, and notifications accessible both on-site and remotely, the Operation Safety System (OSS) is designed to support the operator, to warn on-site teams, to identify the causes of dangerous behaviour, and to reduce both the possibility and frequency of them reoccurring.



See and be seen Lighting Pack



How do you load and unload the MEWP from the truck at night, while ensuring job site safety?

During night-time operations, the MEWP lights help to prevent collisions by illuminating a radius of up to 8 metres (auto-on-off modes). Thanks to the light sensor, the lights are automatically triggered for the visibility and safety of both operator and machine.



Secondary Protection System SPS



How can you prevent the operator from becoming trapped in the aerial platform basket?

This device is automatically activated if the operator is trapped or crushed.



Help the operator **Backup electric pump**



How do you provide assistance when a major defect occurs on the machine?

In the event of operator discomfort or a significant machine breakdown, the backup electric pump can be quickly activated from either the basket or base control.



Always securely fastened **Orange seatbelt**



How do you keep the operator safe at their workstation?

Thanks to its orange colour, the seatbelt is clearly visible to the operator and anyone nearby. No chance of forgetting it!



Assist the operator **Turret rotation information**



How do you avoid a collision if the machine changes direction?

If the turret is oriented at more than 90°, the MEWP will prompt the operator to check the direction.



So intuitive **Human-machine interface (HMI)**



How do you make life easier for your operators and maintenance technicians?

Clearly identified with pictograms and colour codes, the fingertip-controlled dashboards are intuitive, intelligent and harmonised, making diagnoses quick and easy.

OUR COMMITMENT SAFETY - SUPPORT - TCO

This has been our constant focus: making sure that operators work safe with our aircraft access solutions to avoid any downtime in your operations.

Expertise and service on a daily basis

Whether indoor operations or on tarmac, our teams ensure safe and effective delivery of service and maintenance tasks to maximise the efficiency of your people and machines.

To reduce your TCO*

Our teams are committed to providing innovative solutions and continuous improvements to reduce the total cost of ownership* of your machine.



Dealer Network

A network of experts at your service, wherever you are.



Service contracts

3 levels of contracts that provide maintenance anywhere in the world. Entrust the maintenance of your equipment to your dealer.



Maintenance and repair

Minimize downtime, get expert advice and trust qualified professionals to maintain and repair your equipment.



Customized Financing

Buy or lease? Everything is included for the life of your equipment, with no hidden costs and a single point of contact.



Connected machines

This fleet management solution gives you real-time access to your machines' technical information from anywhere at any time. Secure your machine with an access control keypad. Safety first!



Original spare parts

Guaranteed performance and reliability. Ask for original spare parts and maximize the life of your machine and its resale price.



All the info on the QR code of my machine

What could be easier than scanning a QR code to find my machine's standard documentation in my preferred language?



Extended coverage

Protect your business from unexpected and out-of-budget expenses. Get full coverage for parts and labor for up to 6 years or €6,000.

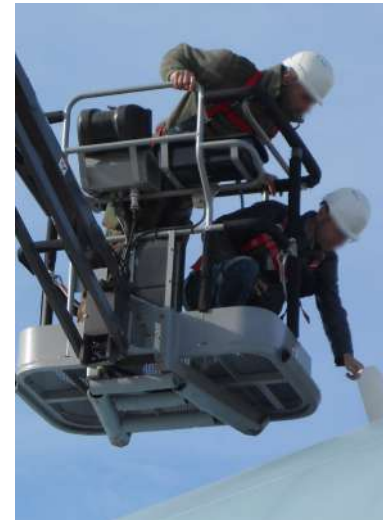



“

What is important, as a fleet manager, is to guarantee and optimize the availability of our aircrafts. That's why I need a machine that is easy to maintain and that allows me to anticipate maintenance! All of this while meeting our safety regulations and being versatile enough to be used anywhere.



B.P. 10249 - 430 rue de l'Aubinière - 44158 Ancenis Cedex - France
Tél. : +33 (0)2 40 09 10 11 - Fax : +33 (0)2 40 83 36 88 - Email : army@manitou-group.com
www.manitou.com

This publication describes the versions and configuration possibilities of Manitou products which may differ in equipment. The equipment shown in this brochure may be standard, optional or not available depending on the version. Manitou reserves the right to change the specifications described and shown at any time without notice. The specifications shown are not binding on the manufacturer. For more details, contact your Manitou dealer. Non contractual document. The logos and visuals of the company are the property of Manitou and may not be used without permission. All rights reserved. The photos and diagrams contained in this brochure are provided for reference purposes only.

Manitou BF SA -Public limited company with a Board of Directors - Share capital: 39,547,824 euros - 857 802 508 RCS Nantes